

NETWORK VIDEO CAMERA

DATA SHEET

THE ALTERNATIVE SOLUTION

FENNEC SERIES



BY



MOTORIZED TURRET T3Z2812IP5MP-AI



5MP - 20FPS

Onvif® COMPLIANT PROFILE S/G/T

TRUE WDR 120DB / IP66

MOTORIZED 2.8-12MM LENS

H.265 & H.264 CODEC

POE (POWER OVER ETHERNET)

AI FEATURES

HUMAN/VEHICLE DETECTION
PERIMETER DETECTION
FACE DETECTION / FACE RECOGNITION
LINE CROSSING DETECTION

45M IR ARRAY LED/STARLIGHT

ALARM/AUDIO: IN/OUT

3 YEARS WARRANTY



MOTORIZED TURRET

MODEL: T3Z2812IP5MP-AI



• RESOLUTION	5MP 2592(H) X 1944(V)
• IMAGE SENSOR	1/2.7" PROGRESSIVE CMOS
• MIN. ILLUMINATION	COLOR 0.01LUX @ F1.2(AGC ON) ; B/W 0 LUX @ IR ON

• SHUTTER	1/5 ~ 1/20000S
• SLOW SHUTTER	SUPPORT
• LENS	2.8 ~ 12MM (MOTORIZED) H.FOV: 102 ~ 31°
• F NO.	F NO. 1.83 (W) ~ 3.32(T):5%
• DAY & NIGHT	IR CUT FILTER WITH AUTO SWITCH
• DIGITAL NOISE REDUCTION	3D DNR
• WDR	120DB

• VIDEO COMPRESSION	H.265 / H.264	• BLC	SUPPORT
• VIDEO BIT RATE	8KBPS ~ 8MBPS	• ROI	SUPPORT
• TRIPLE STREAM	✓ YES	• PRIVACY MASK	SUPPORT

• SMART FEATURE	FACE DETECTION HUMAN/VEHICLE DETECTION PID LCD SOD CC
• SYSTEM COMPATIBILITY	ONVIF (VER. 17.06) PROFILE S/G/T
• INTERFACE	RJ45 10M 100M ETHERNET INTERFACE X1
• LED	4 PCS (ARRAY)
• IR RANGE	UP TO 45M

• SD STORAGE	(MICRO SD/SDHC/SDXC SLOT, UP TO 128 GB)	✓ YES	
• ALARM TRIGGER	1 INPUT / 1 OUTPUT	• WATER PROOF	IP 66
• AUDIO	1 INPUT / 1 OUTPUT (RCA)	• POWER SUPPLY	DC 12V/POE
• VIDEO OUTPUT	NA	• CONSUMPTION	≤ 7.9W
• RESET BUTTON	✓ YES	• DIMENSION	Ø135.56X127.04MM
• POE	✓ YES	• WEIGHT	APPR. 881G

RESOLUTION

- MAINSTREAM (1~20FPS DEFAULT 20FPS) :
5MP (2592x1944) | 4MP (2592x1520)
3MP (2048x1520) (2034x1296) | 1080P (1920x1080)
960P (1280x960) | 720P (1280x720)
- SUBSTREAM :
720P (1280x720) | VGA (640x480) | QVGA (320x240)
- MOBILE STREAM :
VGA (640x480) | QVGA (320x240)

IMAGE SETTINGS

ROTATE MODE	CONTRAST
SATURATION	HUE
BRIGHTNESS	SHARPNESS ADJUSTABLE
FLIP	CORRIDOR MODE

PROTOCOLS

TCP/IP	HTTP	DHCP	DNS	DDNS	RTP	RTSP
PPPOE	SMTP	NTP	UPNP	SNMP	HTTPS	FTP

DIMENSIONS

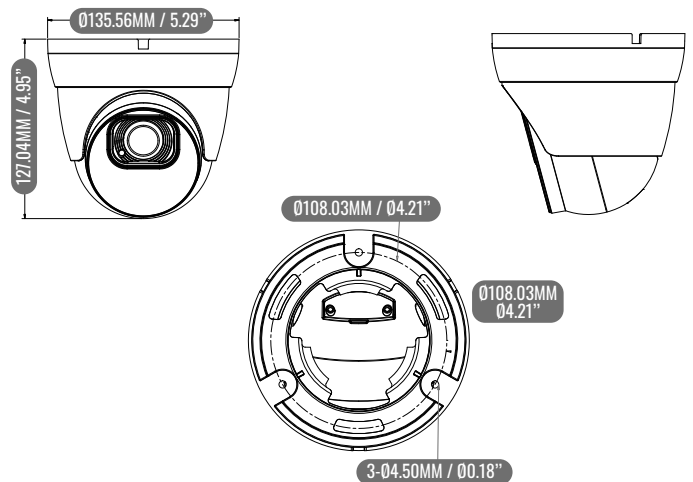

STORAGE CONDITIONS
-30~+60°C



OPERATING CONDITIONS
-30~+55°C

2021 GLOBAL SURVEILLANCE DEVELOPMENT, GSD GROUP AND GSD ARE REGISTERED TRADEMARKS OF GLOBAL SURVEILLANCE DEVELOPMENT GROUP, INC. IN CANADA AND / OR OTHER COUNTRIES. WE RESERVE THE RIGHT TO CHANGE THE DESIGN AND SPECIFICATIONS OF THE PRODUCT WITHOUT NOTICE AND WITHOUT INCURRING ANY OBLIGATION.



T3Z2812IP5MP-AI

ACCESSORIES



EB3BASE3
JUNCTION BOX

WMB5
WALL MOUNT



OR

EB3BASE3-G
GOOSE PENDANT



+

WMB6
WALL MOUNT



COMPLEMENTARY ACCESSORIES



CMB6
CEILING MOUNT BRACKET



PMB6
POLE MOUNT BRACKET



COMB6
CORNER MOUNT BRACKET



EXT-4POE
EXTENDER 4 PORTS POE



INJPOE-25W
INJECTOR POE 25WATTS



IP-COAX-300M
IP OVER COAX EXT