

NETWORK VIDEO CAMERA

DATA SHEET

FENNEC SERIES

THE ALTERNATIVE SOLUTION



BY



MINI VANDAL DOME D2FDA28IP5MP-AI



5MP - 30FPS

Onvif® COMPLIANT PROFILE S/G/T

TRUE WDR 120DB

FIX 2.8MM LENS

IP66

POE (POWER OVER ETHERNET)

AI FEATURES

HUMAN/VEHICULE DETECTION
PERIMETER DETECTION
FACE DETECTION / FACE RECOGNITION
LINE CROSSING DETECTION

25M SMD LED

MICROPHONE

3 YEARS WARRANTY



MINI VANDAL DOME

MODEL: D2FDA28IP5MP-AI



• RESOLUTION	5MP 2592(H)X1944(V)
• IMAGE SENSOR	1/2.7" PROGRESSIVE CMOS
• MIN. ILLUMINATION	COLOR 0.05LUX @ F1.2(AGC ON) ; B/W 0 LUX @ IR ON

• SHUTTER	1/5 ~ 1/20000S
• SLOW SHUTTER	SUPPORT
• LENS	2.8 MM H.FOV: 97° H.VER: 70.57° H.DIA: 128.66
• DAY & NIGHT	IR CUT FILTER WITH AUTO SWITCH (DAY/NIGHT/AUTO/SCHEDULE)
• DIGITAL NOISE REDUCTION:	3D DNR
• WDR	TRUE WDR 120DB

• VIDEO COMPRESSION	H.265/H.264	• BLC	SUPPORT
• VIDEO BIT RATE	8KBPS ~ 8MBPS	• PRIVACY MASK	SUPPORT
• STREAM	TRIPLE	• VIDEO ANALYTICS	SUPPORT

• SYSTEM COMPATIBILITY	ONVIF (VER. 17.06) PROFILE S/G/T
• INTERFACE	RJ45 10M / 100M ETHERNET INTERFACE X1
• LED	10PCS (SMD)
• IR RANGE	UP TO 15M
• SD STORAGE	MICRO SD SLOT, UP TO 256GB

• ALARM TRIGGER	✓ YES	• WATER PROOF	IP66
• AUDIO	✓ YES	• POWER SUPPLY	D 12V/POE
• VIDEO OUTPUT	✗ NO	• CONSUMPTION	≤ 7W
• RESET BUTTON	✓ YES	• DIMENSION	115MM X 90.1MM
• POE	✓ YES	• WEIGHT	APPR 570G

RESOLUTION

- MAINSTREAM(DEFAULT 30FPS/5MP)
5MP (2592X1944) (1-15FPS) | 4MP (2592X1520) (1-20FPS)
3MP (2048X1520) | 1080P (1920X1080) (1-30FPS)
960P (1280X960) | 720P (1280X720)
- SUBSTREAM(DEFAULT 10FPS) (1-15FPS)
720P (1280X720) | VGA (640X480) | QVGA (320X240)
- MOBILESTREAM
VGA (640X480) | QVGA (320X240)

IMAGE SETTINGS

FLIP	CONTRAST
SATURATION	HUE
BRIGHTNESS	SHARPNESS ADJUSTABLE

PROTOCOLS

TCP/IP	HTTP	DHCP	DNS	DDNS	RTP	RTSP
	SMTP	NTP	UPNP	SNMP	HTTPS	FTP

DIMENSIONS

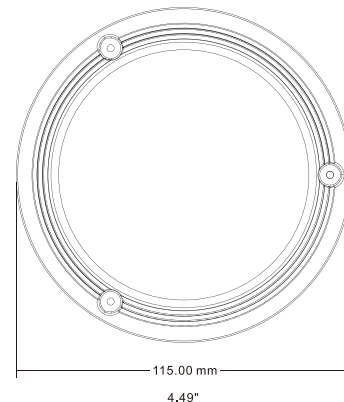
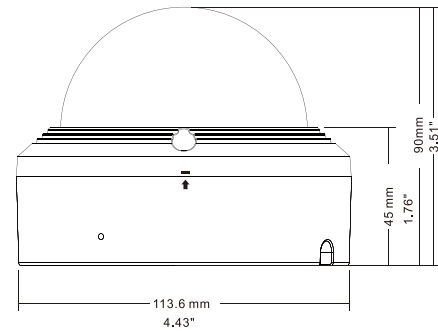

STORAGE TEMPERATURE
-30~+60°C
LESS THAN ≤ 95% RH



OPERATING TEMPERATURE
-30~+55°C

2021 GLOBAL SURVEILLANCE DEVELOPMENT, GSD GROUP AND GSD ARE REGISTERED TRADEMARKS OF GLOBAL SURVEILLANCE DEVELOPMENT GROUP, INC. IN CANADA AND / OR OTHER COUNTRIES. WE RESERVE THE RIGHT TO CHANGE THE DESIGN AND SPECIFICATIONS OF THE PRODUCT WITHOUT NOTICE AND WITHOUT INCURRING ANY OBLIGATION.



D2FDA28IP5MP-AI

ACCESSORIES



 **D2BASE1**
JUNCTION BOX

 **WMB2**
WALL MOUNT



OR

 **D2BASE1-G**
GOOSE MOUNT



+

 **WMB6**
WALL MOUNT



COMPLEMENTARY ACCESSORIES



 **CMB6**
CEILING MOUNT BRACKET



 **PMB6**
POLE MOUNT BRACKET



 **COMB6**
CORNER MOUNT BRACKET



 **EXT-4POE**
EXTENDER 4 PORTS POE



 **INJPOE-25W**
INJECTOR POE 25WATTS



 **IP-COAX-300M**
IP OVER COAX EXT